



ZAKŁAD PRODUKCJI URZĄDZEŃ  
SANITARNYCH  
I ELEKTRYCZNYCH  
"PPRI - EGRZE" SP. Z O.O.



61-248 Poznań  
ul. Działoszańska 10  
tel./fax: (061) 878-95-25

## ZBIORNIKI SPRÓGOWE POWIETRZA

Dyrektywa 97/23/WE D karta nr 4A

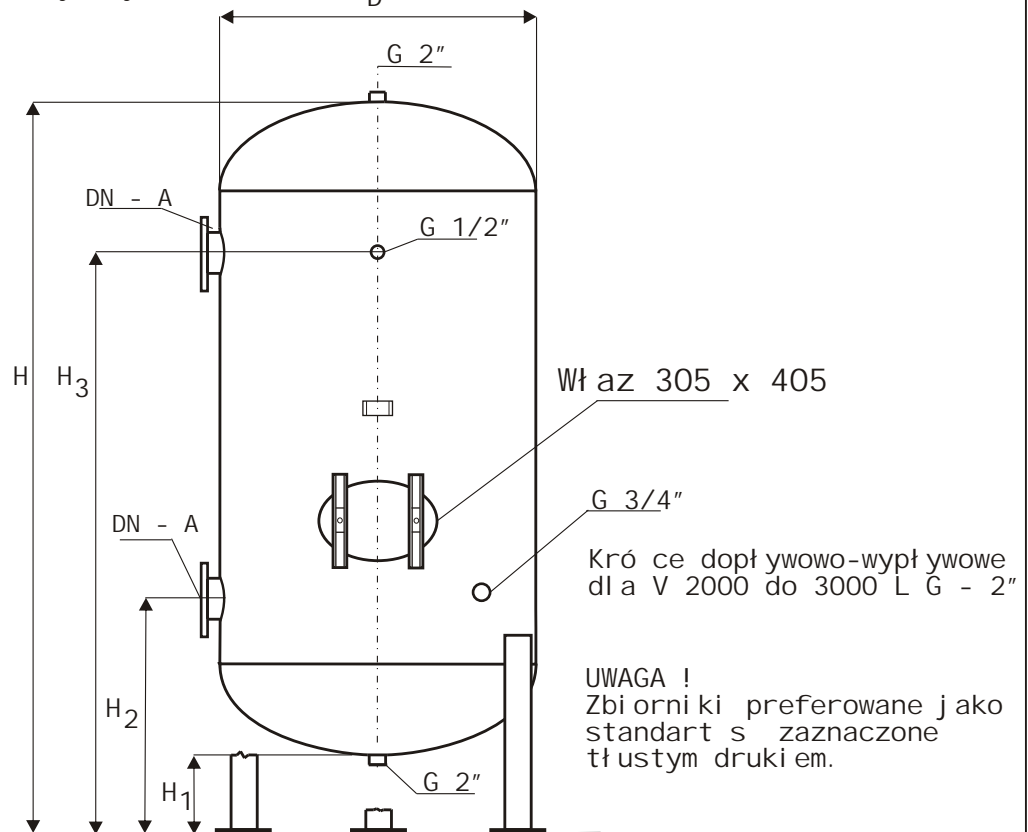

Lp.	TYP	V Litr	PS bar	D	H	H <sub>1</sub>	H <sub>2</sub>	H <sub>3</sub>	DN-A	MASA kg
1.	ZP-2000/10	2000	10	1200	2146	200	666	1680	G 2"	615
2.	ZP-2000/13	2000	13	1200	2146	200	678	1668	G 2"	770
3.	ZP-2000/15	2000	15	1200	2146	200	648	1698	G 2"	770
4.	ZP-2500/10	2500	10	1200	2596	200	666	2130	G 2"	724
5.	ZP-2500/15	2500	15	1200	2596	200	678	2118	G 2"	910
6.	<b>ZP-3000/10</b>	<b>3000</b>	<b>10</b>	<b>1200</b>	<b>3146</b>	<b>200</b>	<b>666</b>	<b>2680</b>	G 2"	<b>920</b>
7.	ZP-3000/10	3000	10	1400	2330	200	716	1830	G 2"	760
8.	ZP-3000/15	3000	15	1200	3146	200	678	2668	G 2"	1070
9.	ZP-3000/16	3000	16	1400	2330	200	708	1822	G 2"	910
10.	ZP-4000/10	4000	10	1200	3996	300	766	3530	100	1100
11.	<b>ZP-4000/10</b>	<b>4000</b>	<b>10</b>	<b>1400</b>	<b>2980</b>	<b>200</b>	<b>716</b>	<b>2480</b>	<b>100</b>	<b>970</b>
12.	ZP-4000/11	4000	11	1400	2980	200	716	2480	100	1170
13.	ZP-4000/16	4000	16	1400	2980	200	716	2480	100	1140
14.	<b>ZP-5000/10</b>	<b>5000</b>	<b>10</b>	<b>1400</b>	<b>3796</b>	<b>200</b>	<b>716</b>	<b>3280</b>	<b>100</b>	<b>1200</b>
15.	ZP-5000/10	5000	10	1600	3080	200	766	2530	100	1200
16.	ZP-5000/11	5000	11	1600	3080	200	766	2530	100	1200
17.	<b>ZP-6000/10</b>	<b>6000</b>	<b>10</b>	<b>1400</b>	<b>4396</b>	<b>200</b>	<b>716</b>	<b>3880</b>	<b>100</b>	<b>1400</b>
18.	ZP-6000/10	6000	10	1600	3580	200	766	3030	100	1350
19.	ZP-6000/11	6000	11	1600	3580	200	766	3030	100	1350
20.	ZP-8000/10	8000	10	1800	3680	200	808	3072	100	1750
21.	ZP-10000/10	10000	10	1800	4520	200	808	3912	100	2150
22.	ZP-12000/10	12000	10	2000	4200	300	966	3630	100	1900
23.	ZP-15000/10	15000	10	1800	6496	200	848	5848	150	3100